

IS-CP4B-PB Manual Call Point – Push Button With resistor Modules For use in Flammable Gas and Combustible Dust Atmospheres

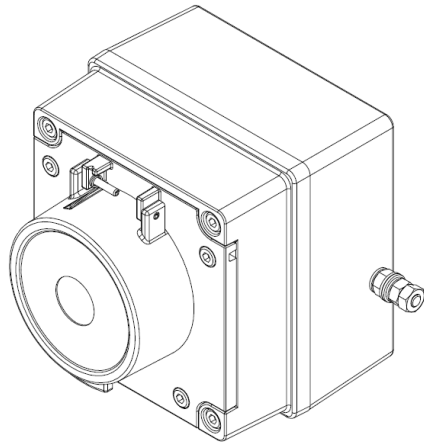

1) Introduction

The IS-CP4B-PB is a push button manual call point which is certified intrinsically safe to the European and International Gas standards. The unit meets the requirements of the ATEX directive 94/9/EC and IECEx scheme.

The call point can be used in hazardous areas where potentially flammable gas atmospheres may be present.

The IS-CP4B-PB has up to two monitoring resistors. The units are Group II, EPL (equipment protection level) Ga. The equipment is certified 'Ex ia IIC T4 Ga' and as such may be used in Zones 0, 1 and 2 with flammable gases and vapours with gas groups IIA, IIB & IIC and temperature classes T1, T2, T3 and T4.

The equipment needs to be installed with ATEX and/or IECEx certified Zener Barriers or Galvanic Isolators.

2) Marking

All units have a rating label, which carries the following important information:-

Unit Type No.:
IS-CP4B-PB Manual Call Point

Code:
Ex ia IIC T4 Ga
IP66

Ui=30V Ii=500mA Pi=1.1W Ci=0 Li=0

-40°C ≤ Ta ≤ +50°C

Certificate No.:
SIRA 09ATEX2287X
IECEX SIR 09.0122X

Epsilon x:  II 1G

CE Marking
Notified body No.  0518

Year/Serial No. i.e. 10/1CP4BPB000001

**WARNING - DO NOT OPEN WHEN AN
EXPLOSIVE ATMOSPHERE MAY BE PRESENT**

3) Type Approval Standards

The beacon has an EC Type examination certificate issued by SIRA and have been approved to the following standards:-

EN 60079-1:2006 / IEC 60079-0:2004
EN 60079-1:2009 / IEC 60079-0:2007
EN 60079-11:2007 / IEC 60079-11:2007
EN 60079-26:2007 / IEC 60079-26:2006

EN 61241-0:2006 / IEC 61241-0:2004
EN 61241-1:2004 / IEC 61241-1:2004

The equipment is certified for use in ambient temperatures in the range -40°C to +50°C and shall not be used outside this range.

4) Installation Requirements

Installation of this equipment shall only be carried out by suitably trained personnel in accordance with the applicable code of practice e.g. IEC

60079-14/EN 60079-14 and IEC 61241-14/EN 61241-14.

Repair of this equipment shall only be carried out by the manufacturer or in accordance with the applicable code of practice e.g. IEC 60079-19/EN 60079-19.

The certification of this equipment relies on the following materials used in its construction:

Enclosure: Aluminium Pressure Die Cast Body
LM6

Through enclosure mechanism: Plastic Nylon Zytel
Injection Moulded

Sealing of enclosure and mechanism: O-ring
Acrylonitrile-Butadiene Rubber

If the equipment is likely to come into contact with aggressive substances, then it is the responsibility of the user to take suitable precautions that prevent it from being adversely affected, thus ensuring that the type of protection is not compromised.

"Aggressive substances" - e.g. acidic liquids or gases that may attack metals, or solvents that may affect polymeric materials.

"Suitable precautions" - e.g. regular checks as part of routine inspections or establishing from the material's data sheet that it is resistant to specific chemicals.

Refer to certificates SIRA 09ATEX2287X and IECEx SIR 09.0122X for special conditions of safe use.

5) Call Point Location and Mounting

The location of the call point should enable ease of access for operation and testing. The unit should be mounted using the 4 off fixing holes which will accept up to M4 sized fixings.

When installing in Zone 0 applications, ensure that the equipment enclosure is protected from impact.

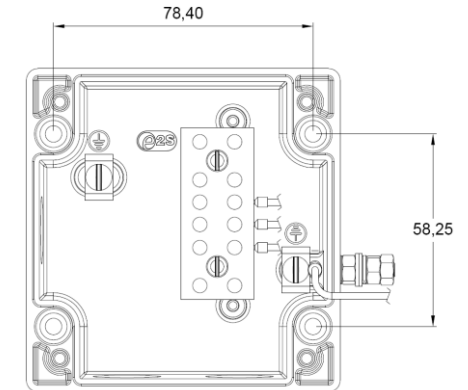

View of base unit showing fixing centres.

To gain access to the mounting holes in the base the front cover must be removed.

This is achieved by removing the 4 off M4 cap head bolts holding on the cover.

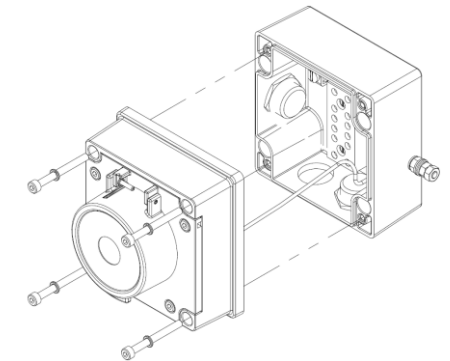

Once the screws are removed the cover will hang down out of the way to gain access to the Ex e terminal block, the internal earth terminal and mounting hole recesses.

6) Earthing

The unit has both internal and external earth terminals.

It is recommended that a cable crimp lug is used on the earth wires.

The internal earth wire is placed under a earth clamp which will stop the cable twisting. This secured by an M4 screw and spring washer.

The external earth lug should be located between the two M5 washers provided and securely locked down with the M5 spring washer and two locknuts.

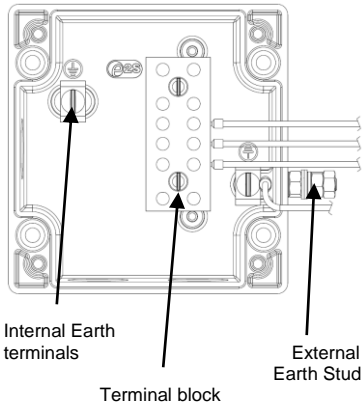

7) Cable connections

There are 3 off cable entries for M20x1.5 cable glands or stopping plugs.

Cable glands or stopping plugs must be rated IP66.

The unit can be wired in a number of different ways depending on the resistor combination selected.

Option 1 – EOL (End of line) Resistor

Option 2 – Series (In line) resistor

Option 3 – Series and EOL resistors

The equipment needs to be installed with ATEX and/or IECEx certified Zener Barriers or Galvanic Isolators.

8) Testing unit operation

The push button unit can be tested without the need to replace any element.

To test, lift the cover lift flap to reveal the push button. The button should be pressed into the body to activate the unit and place it into the operated condition.

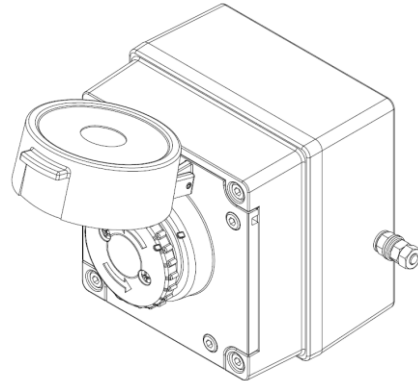

The call point switch will now change over it's contacts to operate the alarm.

Once testing is complete the unit needs to be reset from the operated condition.

Rotate the push button anticlockwise by an angle of 55°, see guide alignment marks on button and cover, shown below (1). The push button should pop back up to its original position.

Ensure that the push button has also twisted back clockwise by 55° to its original position see guide marks on button and cover, shown below (2).

The unit is now reset.

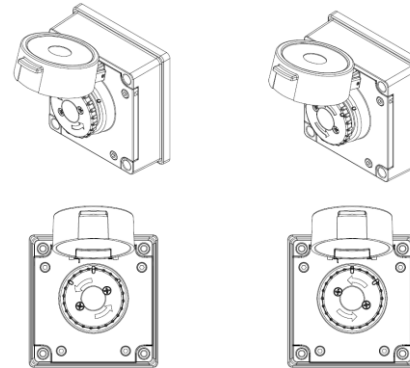

1. On operated unit
Twist push button
Anticlockwise 55°
to reset

2. Button should pop
up and twist back to
original position

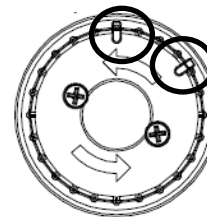

Note: use alignment
marks circled to
indicate the push
button's status
/position.

Unit currently shown
as 'standby
condition'

Resetting an operated unit is the same as resetting a tested unit.

EOL (End Of Line) Resistor

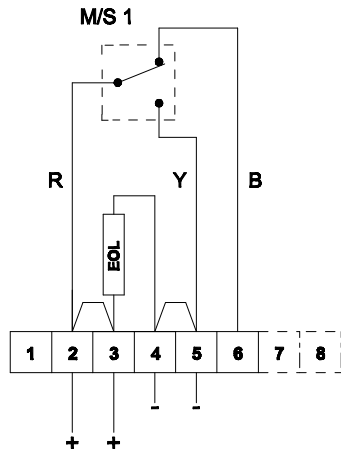

1A - Circuit shown in Unoperated condition
 Terminals +(2,3) & -(4,5) open
 Terminals +(2,3) & (6) closed

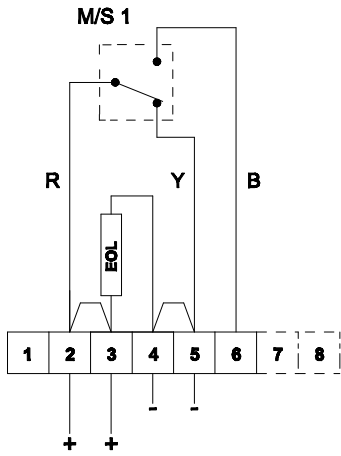

1B - Circuit shown in Operated condition (Button Pressed in)
 Terminals +(2,3) & -(4,5) closed
 Terminals +(2,3) & (6) open

Series Resistor

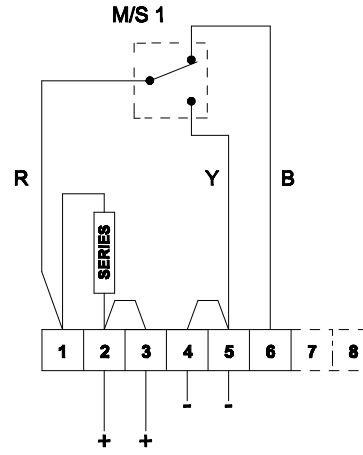

2A - Circuit shown in Unoperated condition
 Terminals +(2,3) & -(4,5) open
 Terminals +(2,3) & (6) closed

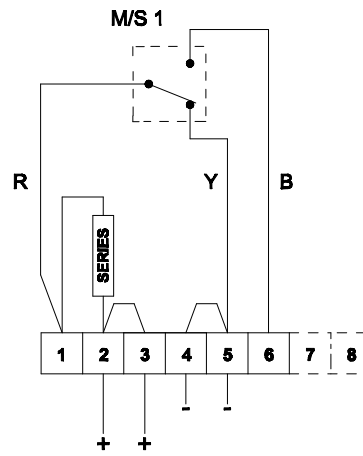

2B - Circuit shown in Operated condition (Button Pressed in)
 Terminals +(2,3) & -(4,5) closed
 Terminals +(2,3) & (6) open

EOL & Series Resistors

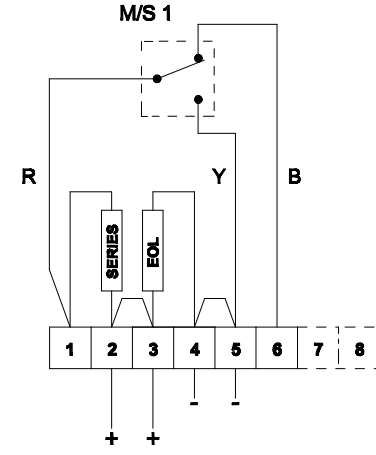

3A - Circuit shown in Unoperated condition
 Terminals +(2,3) & -(4,5) open
 Terminals +(2,3) & (6) closed

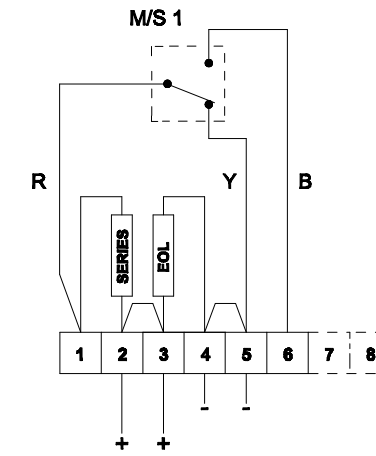

3B - Circuit shown in Operated condition (Button Pressed in)
 Terminals +(2,3) & -(4,5) closed
 Terminals +(2,3) & (6) open

EC DECLARATION OF CONFORMITY



Manufacturer: European Safety Systems Ltd.
Impress House, Mansell Road, Acton
London, W3 7QH, UK

Equipment Type: IS-CP4A,
IS-CP4B,
BExCP5B

Directive 94/9/EC: Electrical and Mechanical equipment for use in explosive atmospheres (ATEX)

Notified Body for EC type Examination: Sira Certification Service
Notified Body No.: 0518
Rake Lane, Eccleston, Chester CH4 9JN, UK

EC-type Examination Certificate: SIRA 09ATEX2287X

Notified Body for Quality Assurance Notification: Sira Certification Service
Notified Body No.: 0518
Rake Lane, Eccleston, Chester CH4 9JN, UK

Quality Assurance Notification: SIRA 05 ATEX M342

Provisions fulfilled by the equipment: II 1G 2D
Ex ia IIC T6 Ga
Ex t IIIC T60 °C Db
(-40 °C ≤ Ta ≤ +55 °C) or
II 1G Ex ia IIC T4 Ga
(-40 °C ≤ Ta ≤ +55 °C) or
II 2D
Ex t IIIC T70 °C Db
(-40 °C ≤ Ta ≤ +50 °C)

Standards applied: EN 60079-0:2006
EN 60079-0:2009
EN 60079-11:2007
EN 60079-26:2007
EN 61241-1:2004

Directive 2004/108/EC: Electromagnetic Compatibility Directive (EMC)

Standards applied: EN 61000-6-1:2007
EN 61000-6-2:2005
EN 61000-6-3:2007
EN 61000-6-4:2007

The standards EN 60079-0: 2006, EN 60079-11:2007 and EN 61241-1:2004 are no longer harmonized. The requirements of these standards have been checked against the harmonized standards EN 60079-0:2009, EN 60079-11:2012 and EN 60079-31:2009 and there were no major technical changes affecting the latest technical knowledge for the products listed above.

On behalf of European Safety Systems Ltd., I declare that, on the date the equipment accompanied by this declaration is placed on the market, the equipment conforms with all technical and regulatory requirements of the above listed directives.

A handwritten signature in black ink, appearing to read 'Martin Streetz'.

Martin Streetz
Quality Assurance Manager

Date and Place of Issue: London, 04/07/2012
Document No: DC-008-Issue_C